

indication of pressure at the handpiece.

If you do not have an in-line gauge, adjust handpiece pressure until the gauge in the control unit reads slightly higher than the handpiece manufacturer's recommendation.

Repeat this procedure for each handpiece.

Assistant's Instruments

Instruments

The 6570 package includes an autoclavable HVE, an autoclavable SE, and a Quick-Clean syringe. All three come with their own operating and maintenance instructions.

Holder Bar

The three position holder bar has two adjustments (see *figure 2*): the angle of the holder bar and position of the stop screw.

To change the angle of the holder bar, loosen the set screw which holds it in place, rotate the bar to the desired position, and retighten the set screw.

The stop screw can be removed and placed in any one of four threaded holes in the block to provide different stop points for the holder bar.

Solids Collector

The solids collector is mounted on a swing-away arm, mounted under the counter. It contains a screen which should be cleaned, or replaced, periodically.

Air Water Accessory Panel

This panel provides a quick-disconnect source of both air and water. The air is controlled by an on-

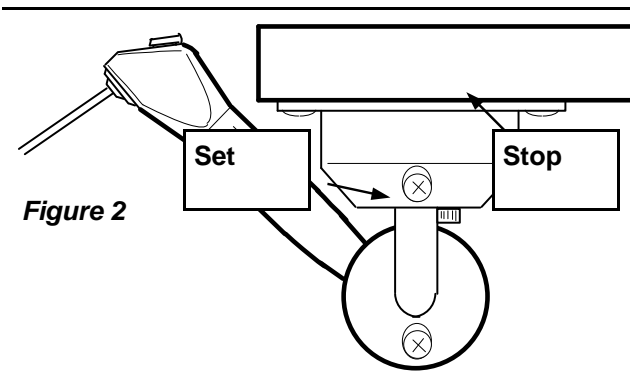

Figure 2

off toggle located directly above the 3/8" QD fitting. The water is controlled by a needle valve directly above the 1/4" water QD. Both QD fittings contain an internal shut-off mechanism; water or air will shut off automatically when the connection is broken.

Foot Control

Pressure to any part of the foot control disc provides drive air to the active handpiece. Increased pressure provides increased drive air. Stepping on the foot control also turns on air and water coolant.

Water coolant can be shut off by flipping the wet/dry toggle to the off position (away from the blue dot).

Cleaning and Maintenance

Note

Do not use powdered cleansers, scouring pads, or abrasive scrubbers on any of the finished metal surfaces of this system (for example, the foot control disc or the autoclavable syringe). Sodium Hypochlorite will also damage these surfaces.

Control Unit and Handpiece Holders

These components can be cleaned with any commonly available surface disinfectant. Some disinfectants can cause discoloration with repeated use. This can be minimized by frequent cleaning with soap and water. If you use an Iodophor, follow up with an Iodophor Neutralizer.

Pub No. 91196, 3-15-95



Committed to Innovation

**Operating Instructions for the
System 6000, Model #6565,
With Assistant's Instruments (6570)**

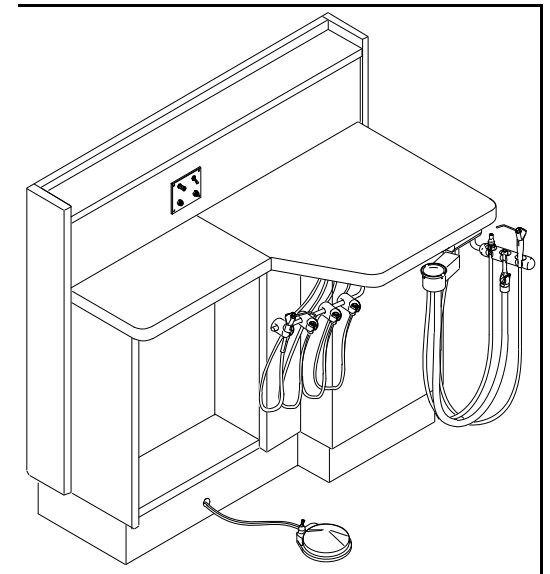

Asepsis Automatic Control

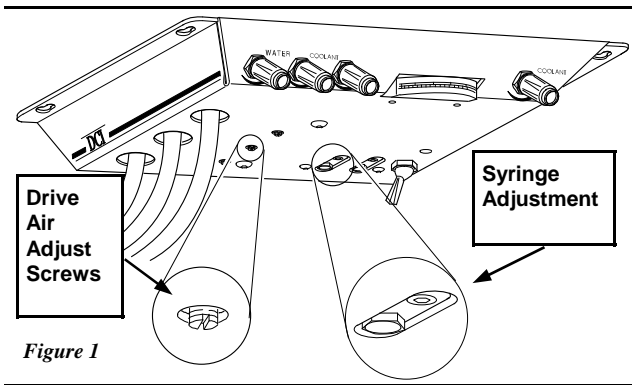

Figure 1

Handpiece Holders

The automatic handpiece holders are attached to a swing-away arm which is mounted to the underside of the counter-top. With the master air toggle in the on position, the handpiece may be activated by depressing the foot control. Speed of the handpiece is also regulated with the foot control.

The position of the handpiece holders is adjustable. See the section below on adjustments.

Controls (figure 1)

The **master on-off toggle** activates the air and water automatic shut-off valves that supply air and water to the entire system. It is located on the underside of the control head, in the right rear corner.

There is a **water coolant flow control knob** for each of the three handpieces. They are located on the front of the control head, to the left of the pressure gauge.

The **air coolant flow control knob** is on the right side of the control head, toward the back.

The **drive air pressure controls and the syringe flow adjustment screws** are located on the underside of the control unit. See the section below on adjustments.

Syringe

The system comes with a Deluxe Autoclavable

Syringe. The holder for the syringe is on the far left side of the holder bar. An instruction booklet is provided.

Adjustments

Syringe Block

Flow control screws for the syringe are located on the underside of the control unit. When facing the unit, the screw for air is on the left, the screw for water is on the right (see figure 1).

Turn the hex nuts clockwise for more air or water, counter-clockwise for less. A 3/32" ball driver is provided in the syringe repair kit.

Handpiece Holders

The handpiece holders are attached to the tool bar with two set screws. To reposition a holder, loosen the set screws in the bottom of the holder, position as desired, and retighten the screws. You will need a 3/16" hex key.

Handpiece Coolant Flow Control

Note

All of the following adjustments should be made with a bur in the handpiece. Running a handpiece without a bur installed can damage the handpiece.

Air Coolant

Place the wet/dry foot control toggle in the dry position (away from the blue dot).

Press on the foot control disc until the handpiece is running at half speed. While the handpiece is running, turn the air coolant flow control knob to provide a strong flow of air. Turn the knob counter-clockwise to increase the flow; turn it clockwise to decrease the flow. This adjustment affects all three handpieces.

Water Coolant

Water coolant flow adjustments are made independently for each handpiece.

To adjust water coolant flow, move the wet/dry toggle

on the foot control to the wet position (toward the blue dot).

Press on the foot control disc until the handpiece is running at half speed.

While the handpiece is running, turn the corresponding water coolant flow control knob to provide a fine mist of water around the bur (the knobs are arranged across the bottom of the control head in the same order as the handpiece holders\tubings). Very little water coolant is required. Turn the knob counterclockwise to increase the flow, clockwise to decrease the flow.

Repeat this procedure for the other two handpieces.

Drive Air

You will need a small flat-bladed screwdriver to make this adjustment. To determine the recommended drive air pressure for your handpieces, refer to the handpiece manufacturer's literature.

Drive air adjustment screws are located on the underside of the control unit. The handpiece pressure gauge is on the front panel (see figure 1).

Install a bur in the handpiece you are going to adjust. Install a DCI handpiece pressure gauge (DCI catalog number 7263) below the handpiece. Trace the tubing from the handpiece to the control block to determine which adjustment screw will affect the handpiece you have selected. Position the screwdriver in the adjustment screw. Press on the foot control disc until the handpiece is running at maximum speed.

Turn the adjustment screw counter-clockwise for less pressure, clockwise for more. Adjust to the manufacturer's recommendation. Due to pressure loss along the tubing, the handpiece pressure gauge in the control unit will read slightly higher (14 to 16 psi) than what is actually available at the handpiece. The in-line gauge gives an accurate