

# FOOT CONTROL REPAIR KIT, PN 6165

## Installation Instructions

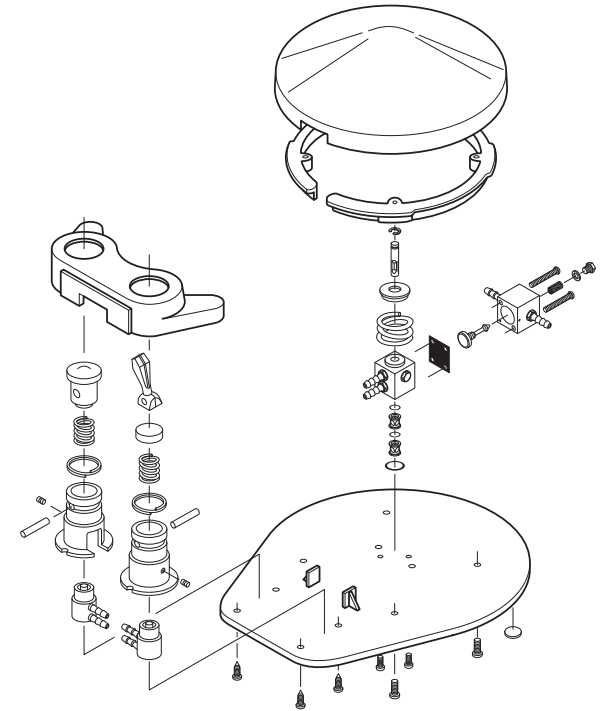

10. Set the relay on top of the valve body, making sure all three holes in each part are aligned.
11. Thread the screws through the relay and into the valve body. Torque firmly; the diaphragm seal must be airtight in order to work properly.
12. Make sure that the large compression spring and the stem are in place on top of the valve body. Place the foot control disc over the base plate.
13. While holding the disc in place, turn the foot control over. Reattach the disc using the four Phillips head screws. It may be necessary to move the plastic retaining ring around in order to find the holes.
14. Your FC is now ready for use.



## FOOT CONTROL REPAIR KIT, PN 6165 INSTALLATION INSTRUCTIONS

This foot control repair kit contains all of the parts needed to rebuild the relay valve in any of DCI's relay-equipped foot controls:

- 6400, 6403, 6409, 6426 Standard w/Relay
- 6405, 6407, 6414, 6436 Chip Blower, w/Relay
- 6410, 6411, 6423, 6435 Wet/Dry, w/Relay
- 6415, 6416, 6424, 6438 Wet/Dry, Chip Blower w/Relay
- 6420, 6422, 6432, 6437 Scaler

This kit includes:

- One stem w/O-Rings PN 6098
- Compression spring PN 9029
- One plug PN 12444
- One diaphragm PN 9012

These parts are identified in Figure 1 below:

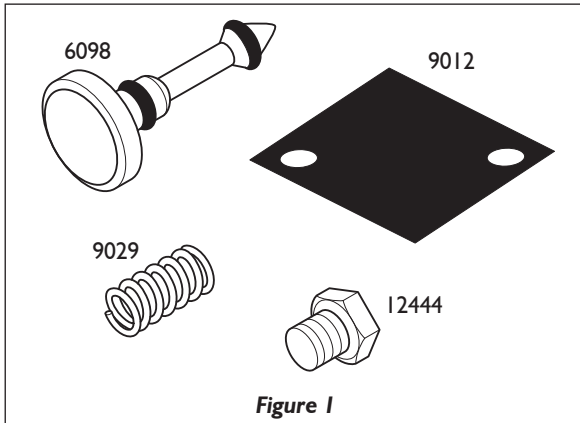

To install this kit, you will need:

- Phillips head screwdriver
- 1/4" hex wrench
- A pointed instrument, such as a dental pick.

**Caution: Be sure air supply to FC is off before proceeding.**

## FOOT CONTROL REPAIR KIT, PN 6165 INSTALLATION INSTRUCTIONS

1. To gain access to the relay, it will be necessary to remove the foot control disc. Remove the four Phillips head screws on the bottom side of the base plate as shown in Figure 2.
2. Turn the foot control right side up while holding the disc on. Lift the disc off, exposing the valve body and relay valve.
3. Remove the two screws that attach the relay to the valve body, as shown in Figure 3.

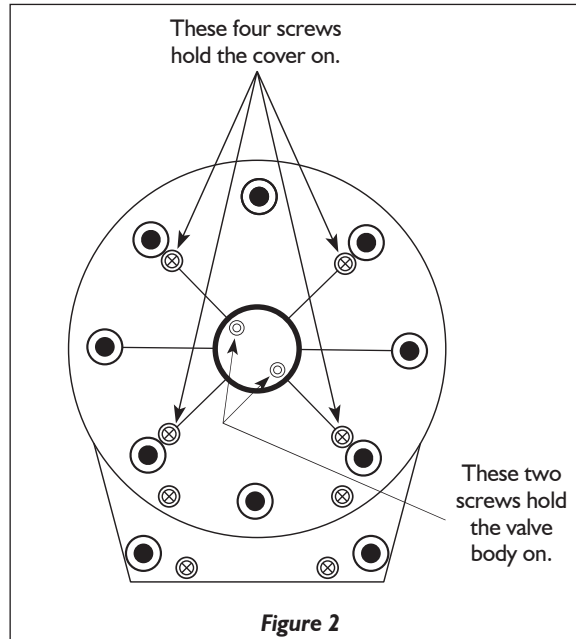

### NOTE

**IT IS NOT NECESSARY TO REMOVE THE VALVE IN ORDER TO REBUILD THE RELAY. HOWEVER, THE LARGE COMPRESSION SPRING AND THE VALVE BODY STEM WILL BOTH BE LOOSE ON TOP OF THE VALVE BODY WHEN THE FOOT CONTROL DISC IS REMOVED. BE CAREFUL NOT TO LOSE THESE PARTS WHILE WORKING ON THE RELAY.**

## FOOT CONTROL REPAIR KIT, PN 6165 INSTALLATION INSTRUCTIONS

4. Separate the relay from the valve body. Remove and discard the diaphragm.
5. Using a 1/4" hex wrench, remove the plug from the rear side of the relay and pull out the small compression spring underneath it. You may need to use a dental pick or other sharp instrument to remove the spring.
6. With the spring removed, push the dental pick into the hole. Press on the bottom end of the stem to force it out the other side. Remove the stem.
7. Press the new stem into place.
8. Place a washer over the plug and thread it into place. Torque firmly, but be careful not to deform the washer.

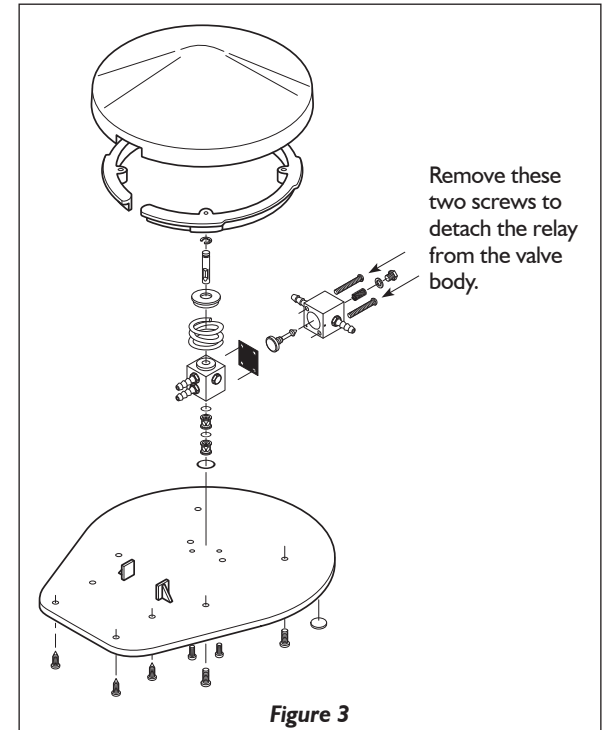

9. Position the diaphragm over the holes in the valve body. One of the holes in the diaphragm will be unused.