

DENTAL LIGHT HANDLE

Upgrade

DCI **EDGE**

INSTALLATION INSTRUCTIONS

NOTES ON INSTRUCTIONS

Tools needed will be called out at the start of each section.

Do not discard any fasteners unless specified in the assembly step.

Illustrations for assembly reference can be found on Pages 2-4 with matching step numbers.

LIGHT HEAD REMOVAL - 5/32IN. HEX KEY



CAUTION: Flex Arm must be in the raised position prior to Light Head removal. Removing the Light Head with the Flex Arm in a lowered position will cause the Flex Arm to rise with force that can injure the User and damage the equipment.

1. Lift the beauty ring and remove the two socket head screws that secure the light head to the front knuckle of the flex arm.
2. Pull the Light Head down from the knuckle to expose and disconnect the wire harness.
3. Place the Light Head on a flat, clean work surface. Set the screws and the beauty ring aside for use later. Remove the light shield, then turn the light head over.

COVER REMOVAL - #2 PHILLIPS SCREWDRIVER

4. Remove the chassis bottom cover and the two screws that secure the bottom of the Front Cover. Turn the light head over.
5. Remove the two screws in the back cover and carefully lower the front cover to the work surface. **Do Not Pull on the Front Cover** as this could damage the touch pad ribbons rendering the light head useless.

HANDLE REPLACEMENT - #2 PHILLIPS SCREWDRIVER, 5/32IN. HEX KEY, 1/8IN. HEX KEY

6. Remove the existing old handles from the chassis and discard .
7. Thread match the old handle fasteners with either of the kitted 10-24 socket head screws or the 10-32 button head screws. After the thread match is made, discard the old handle fasteners.



NOTE: Failure to properly thread match the fasteners could damage the threads in the chassis requiring replacement of the light head assembly.

8. Install the new handles to the chassis using the thread matched fasteners with the supplied internal tooth lock washers (10-24 socket head shown in illustration) and tighten with a hex key.

COVER AND HEAD INSTALLATION - #2 PHILLIPS SCREWDRIVER, 5/32IN. HEX KEY

Notes on Re-assembly

Complete Steps #5 thru #1 for re-installation of the covers and light head.

When installing the front cover, ensure that the touch pad ribbons are tucked into the front cover and are not getting pinched or crushed in the cover set.

INSTALLATION INSTRUCTIONS

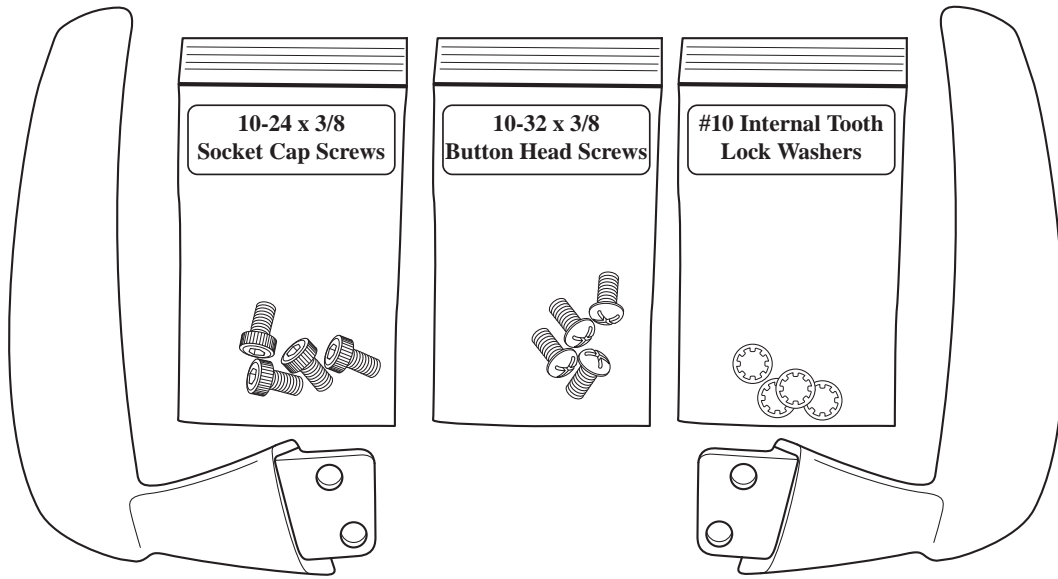

Left and Right Handle Upgrade Kit

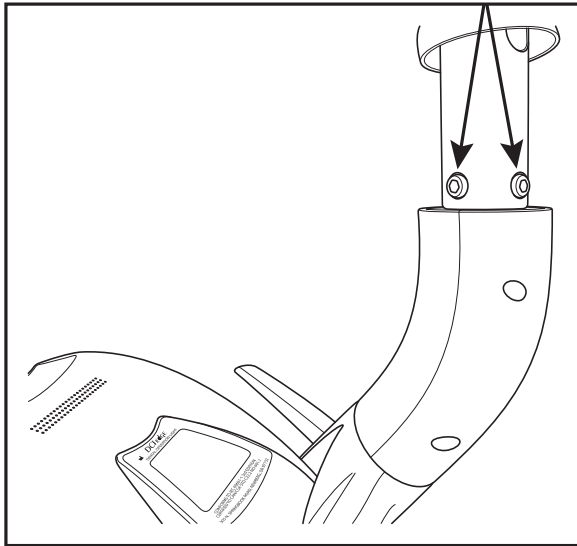

Step #1



Steps #2, #3

INSTALLATION INSTRUCTIONS

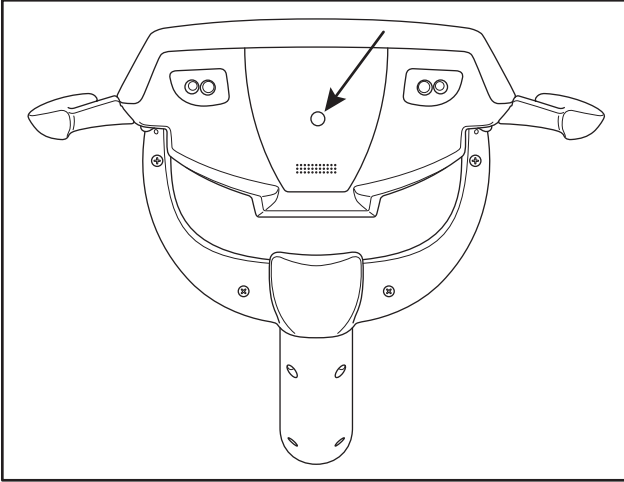

Step #4

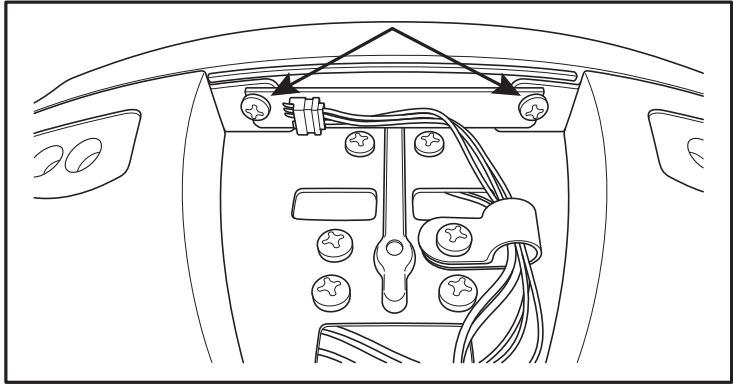

Step #4

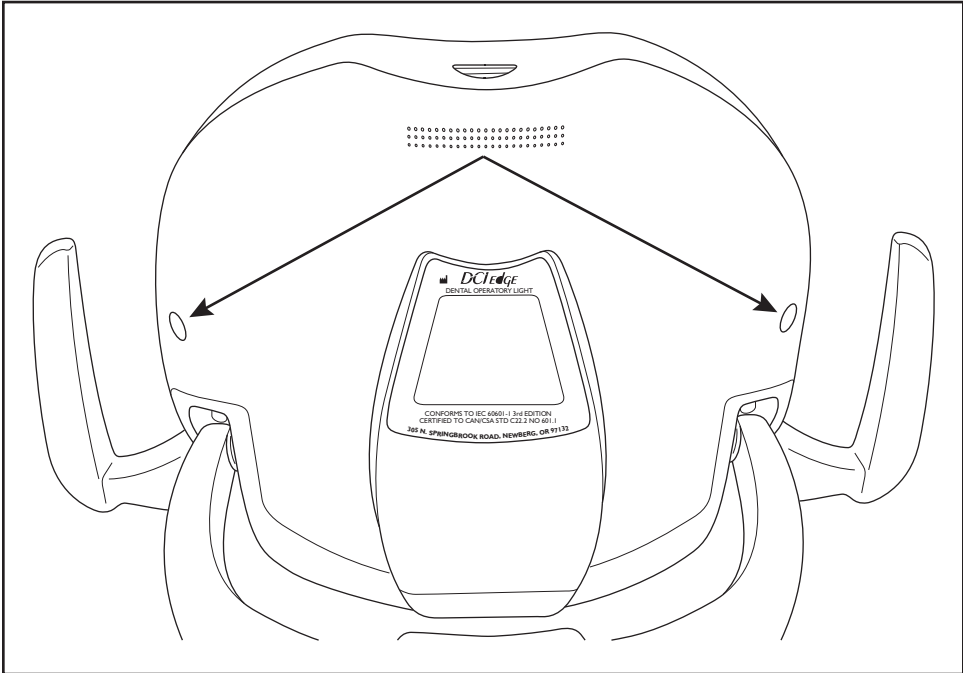

Step #5

INSTALLATION INSTRUCTIONS

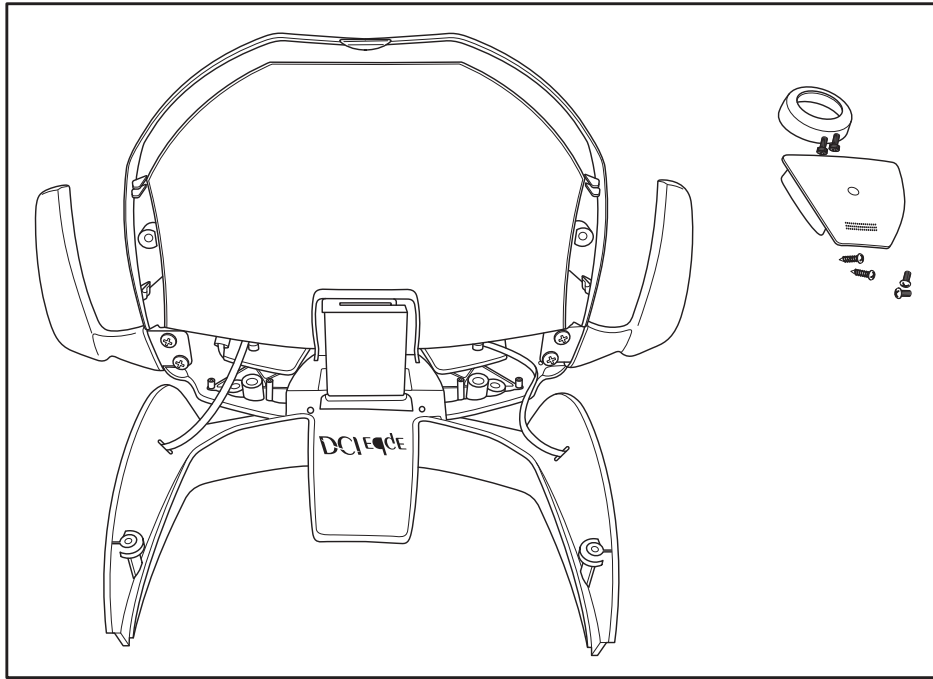

Step #5

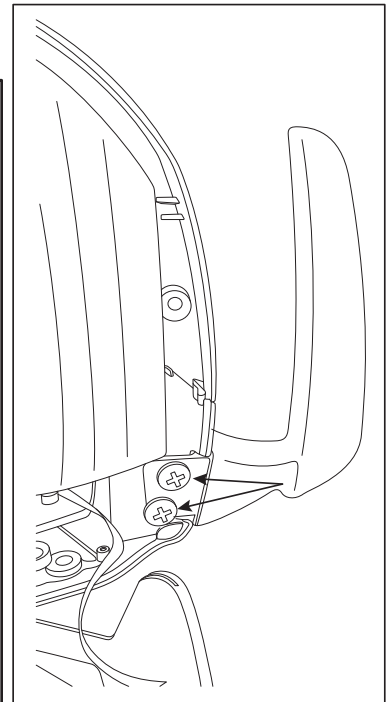
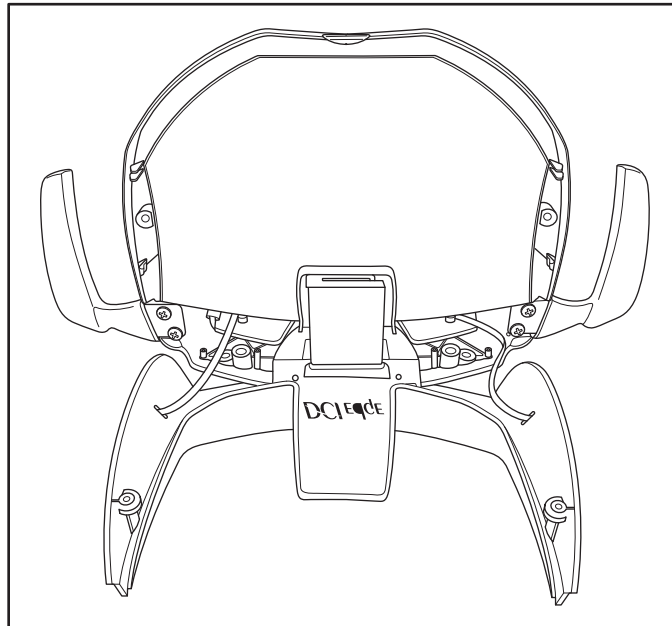
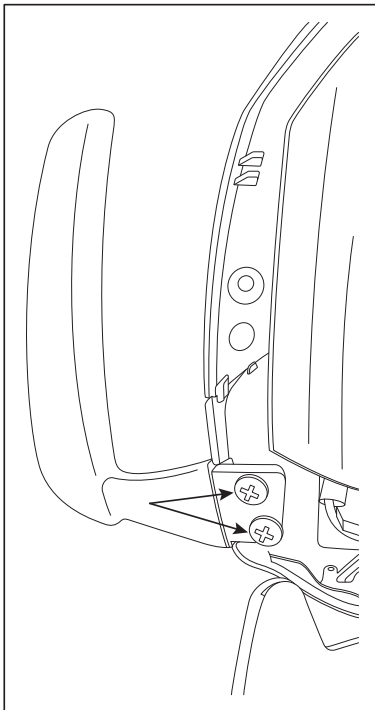

Steps #6 - #8

DCI Edge