

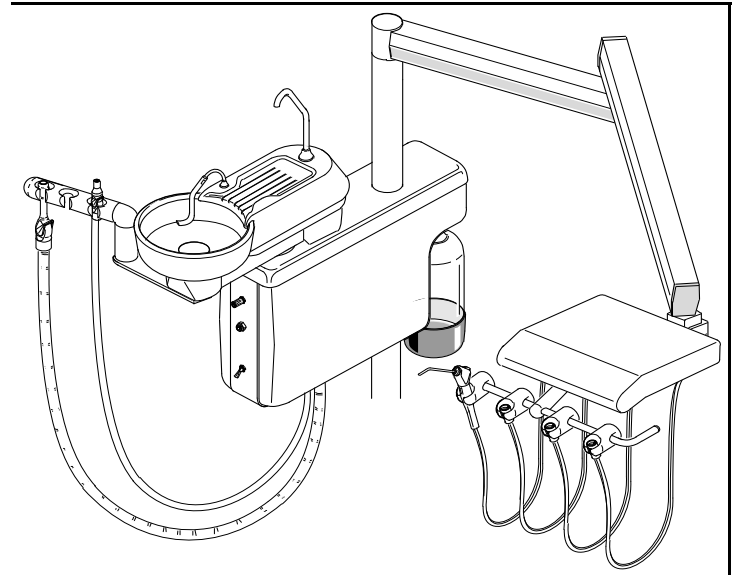

Committed To Innovation

**Installation Instructions for the
System 6000
Model #6505**



Contents

Checklist	Page 1
Install Post on Chair Mount Bracket	Page 2
Install Post Mounted Utility Center	Page 2
Install Cuspidor	Page 3
Install Arm Assembly and Control Head, 40" Post	Page 4
Install Arm Assembly and Control Head, 22" Post	Page 5
Install Light Post Extension	Page 5
Install Floor Utility Sub-Assembly	Page 6
Make Tubing Connections in the Post Mounted Utility Center	Page 6
Connect Foot Control	Page 6
Connect Assistant's Instruments	Page 8
Connect Drain Tubing in Floor Box	Page 8
Turn on System and Adjust	Page 8
Install Water Heater (Optional)	Page 9
Install Fiber Optic Handpiece Tubing	Page 12

The 6505 system comes with the following items:

- ◆ Arm and control head assembly, with handpiece tubings and umbilical installed. The control head assembly also includes:
 - Stainless steel tray with non-skid pad
 - Deluxe Autoclavable syringe
- ◆ Post mounted utility center, including:
 - Vacuum canister
 - Self-contained water system
- ◆ Gravity Drain Cuspidor, with bowl mounted assistant's instruments.
- ◆ Floor utility sub-assembly, including:
 - Two manual shut-off valves, one for air, one for water
 - Two master shut-off valves
 - Two mini-regulators
- ◆ Mounting post, either 40" or 22"
- ◆ Wet/Dry foot control
- ◆ Optional light post extension kit.
- ◆ Chair adaptor

You will need the following tools and materials to install the system:

Level, preferably with built-in magnet
 5/32", 1/8", 1/4" and 3/16" hex keys
 3/4" open end or box end wrench
 1/4" and 1/8" tubing sleeves and sleeve tools.
 Teflon tape
 Large crescent wrench
 Appropriate hardware and tools to mount the chair adaptor.

1. **Install the chair adaptor.** Follow the chair manufacturer's recommendations.
2. **Install the post on the chair mount bracket (*Figure 1*).**

Place the post in the chair mount collar. Make sure the end of the post with the aluminum crush bearing goes into the collar.

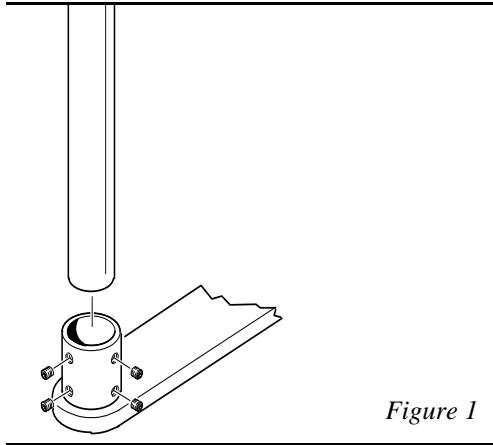

Position the post in the collar so that the slot for the umbilical faces the head of the chair. This will ensure proper placement of the PMU and other components when they are installed.

With a level and a hex key, adjust the eight set screws in the chair mount bracket to set the post in a perfectly vertical position. Tighten the set

screws.

Figure 1

3. Install the post mount utility center on the post (Figure 2).

In order to install the post mount utility center (PMU), you will need

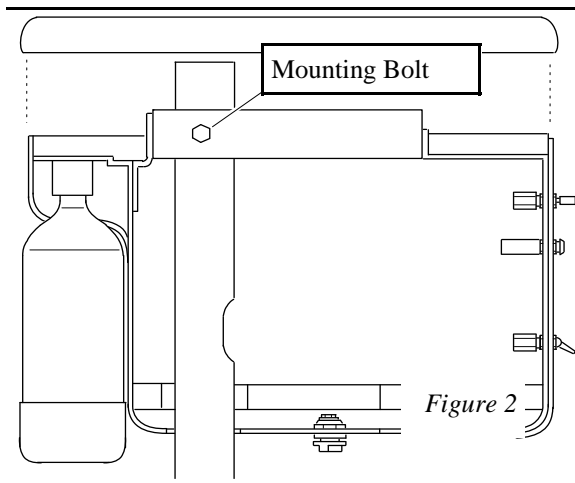

to remove the side covers:
On the bottom of the PMU, locate two black, 1/2" diameter knobs. Turn these counterclockwise to loosen. Loosen the knobs until you feel the threads disengage; they are held in place with a washer so they will not fall out.

Pull the side covers off of the PMU and set them aside. Slide the PMU onto the mounting post and

Figure 2

4. Remove the end cap from the rigid arm, as shown in **Figure 5** (1/8" hex key).
5. In the open end of the rigid arm, locate the unused 1/8" orange line. This line is unconnected in the control head. Pull it out from the

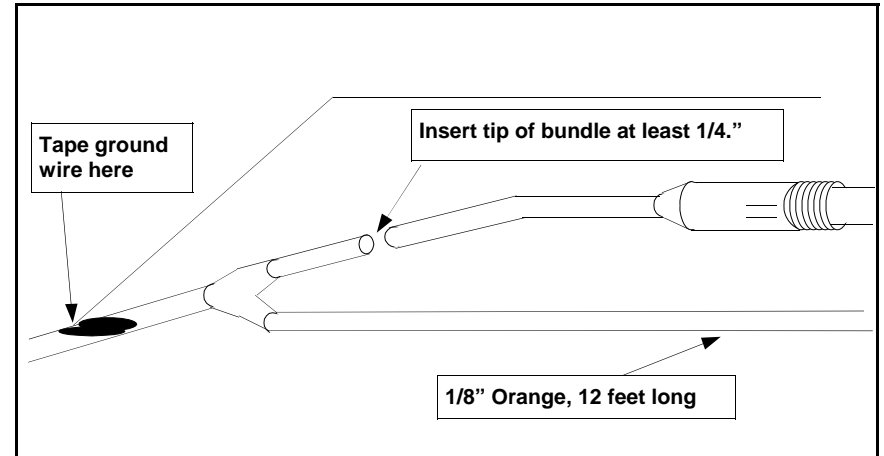

Figure 7

control head until it hangs free from the open end of the rigid arm (There are two 1/8" orange lines. The unused line is labelled "A" in the control head).

6. One end of the fiber optic handpiece tubing has a nut attached. Hang the nut in one of the handpiece holders on the control head. Route the other end of the tubing (with the fiber optic bundle and ground wire) into the control head, through the hole indicated in **Figure 2**. Cut the handpiece tubing to the desired length and connect to the handpiece block.

Note:

Handle the fiber optic bundle with care. Excessive bending can damage the fibers.

7. Route the fiber optic bundle and ground wire through the hole indicated in **Figure 2**, along the short control arm, through the knuckle at the end and along the bottom of the flex arm. Feed them through the knuckle at the end of the flex arm and bring them out through the open end of the rigid arm, next to the 1/8"orange tubing.

the short control arm, as shown in **Figure 3** (3/32" hex key).

3. Remove the bottom access strip from the flex arm, as shown in **Figure 4** (5/64" hex key).

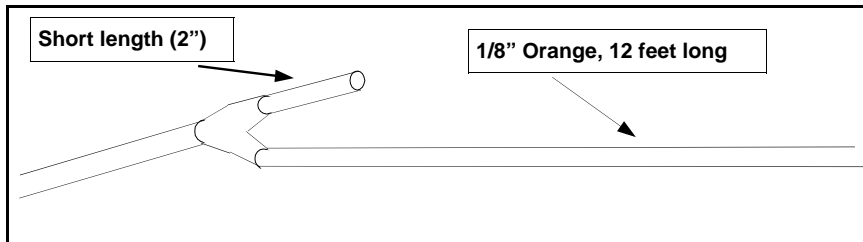

Figure 6

position it so that:

- ◆ The hole in the post for the umbilical is inside the PMU.
- ◆ There is at least 1½" of clearance between the bottom of the PMU housing and the chair mount collar.
- ◆ The cuspidor clears the chair arm.
- ◆ The cup filler clears the delivery system arm.

Within these limits, height of the PMU can be set to the user's preference.

The cuspidor module on the PMU should face the head of the chair. Tighten the mounting bolt with a 3/4" wrench. Leave the covers off so you can make tubing connections after all of the system components are installed.

4. Install the cuspidor (**Figure 3**).

The cuspidor module is already installed on the PMU and plumbing connections have already been made. However, the bowl, spouts and cover are shipped separately to protect them from damage.

To install the bowl, simply press the bottom of the bowl into the gray drain fitting in the cuspidor module. There are two large black o-rings in the bottom of the cuspidor bowl. Press until you feel the o-rings seat securely into the drain fitting.

Lay the cover over the top of the cuspidor module so that the holes in the cover align with the spout connections on the module. On the module, there is a small stud next to the hole for the cup-fill spout. Make sure it goes through the hole provided for it in the cover. The bowl fits into a cut-out in the end of the cover.

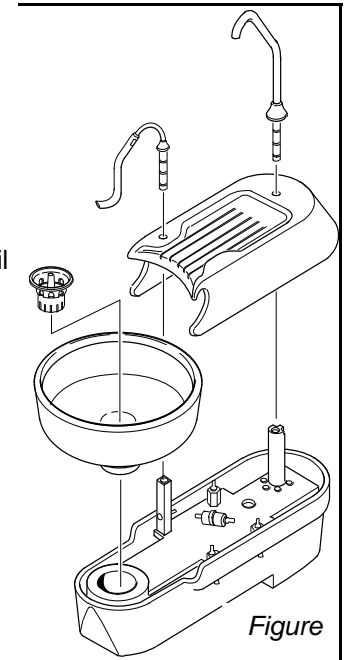

Figure

The cup-fill and flush spouts will hold the cover in place.

Install the cup-fill spout. Just above the o-rings on the spout, there is a flange. On the underside of the flange, there is a small hole which mates with the stud on the module to ensure proper

placement of the spout over the cover. Make sure the stud and the hole are aligned, then press the spout into place.

Install the flush spout. Press the spout into its mounting hole next to the bowl until the flange on the spout contacts the cover. The flush spout swivels to allow a variety of positions in the bowl.

Extend the assistant's instrument tool bar and place the HVE and the SE in the holders.

5. Install the arm assembly and the control head on the mounting post.

WARNING

The arm assembly for this unit is spring loaded. Do not remove the shipping strap from the arm assembly until the unit is fully installed. Bodily injury could result from working with the arm assembly unrestrained.

A. Follow these instructions if your system came with a 40" post and a post mounted flex arm (Figure 4).

If your system came with a 22" post and a top mounted flex arm (and optional light post extension kit), skip to section "B".

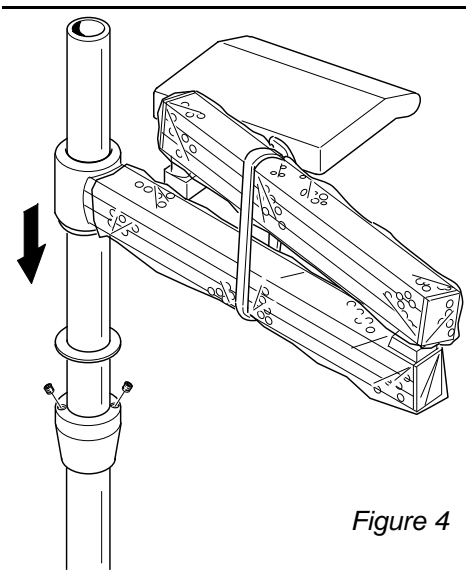

Figure 4

Leave the shipping strap on the arm assembly during installation.

Slide the collar over the post. Position the collar at the desired height and tighten the set screws using a 3/32" hex key.

Slide the thrust washer over the post and down onto the top of the collar.

Install the arm assembly on the post and slide it down on top of the thrust washer.

Route the umbilical from the rigid arm into the hole in the post, down to the slot, and out of the post into the PMU.

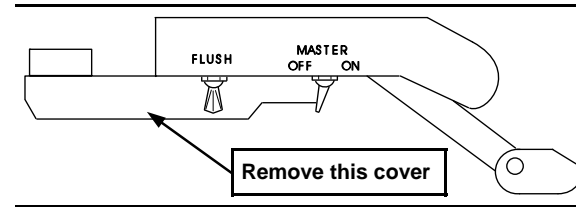

Figure 3

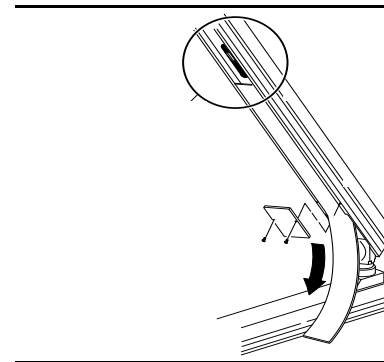

Figure 4

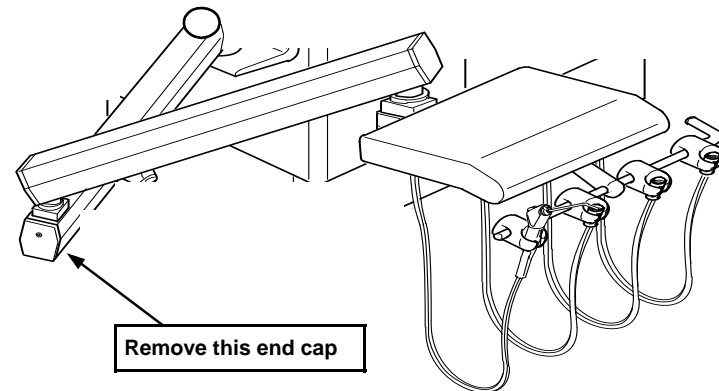

Figure 5

2.

Remove the cover from the bottom of

Instructions for Installing Fiber Optic Tubing Bundle in DCI 52" Flex Arm

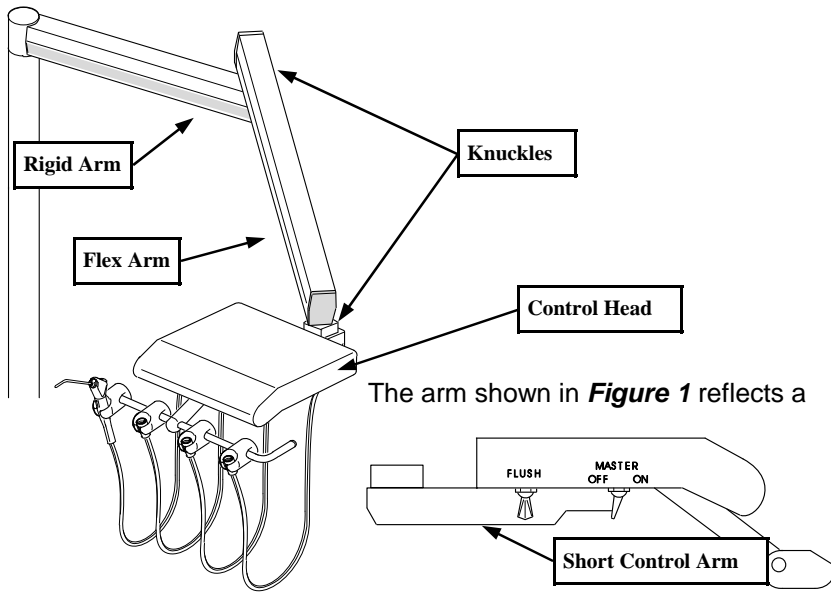

Figure 1

typical 52" flex arm, used in the production of the 6500. Terms identified in **Figure 1** will be used throughout the instruction.

To route a fiber optic bundle from the control head, through the arm and post, to the PMU, begin by disassembling as follows:

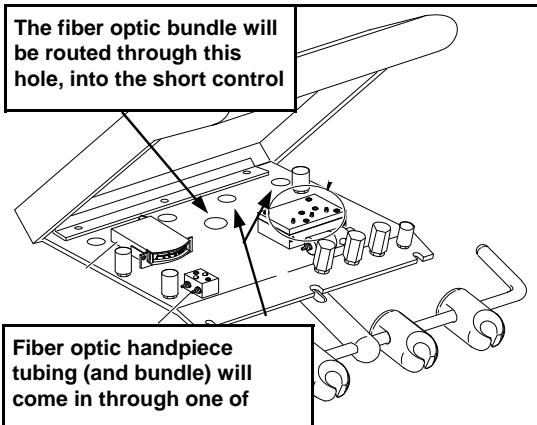

Figure 2

Remove the shipping strap and wrapping from the arm.

B. 22" post and top mounted arm (Figure 5).

Leave the shipping strap on the arm assembly during installation.

If you have a light post extension kit, slide the extension clamp over the mounting post before installing the arm.

Position the thrust washer over the bushing in the end of the mounting post.

Thread the umbilical from the end of the arm into the top of the post.

Slide the stud on the end of the arm through the washer and into the bushing in the top of the post.

Pull the umbilical out of the post through the slot and into the PMU.

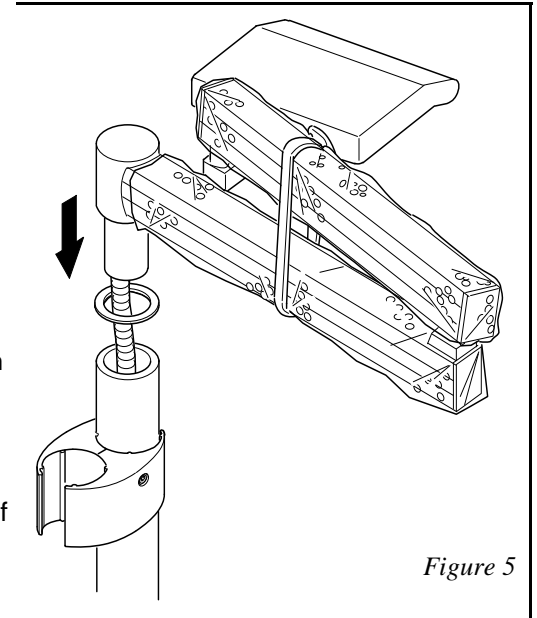

Figure 5

6. To install the light post extension (Figure 6, next page):

Insert the extension post into the extension clamp. Make sure the bushing for the top mounted light faces up. Position the extension clamp and post at the desired height on the mounting post. Tighten one set screw on each side of the clamp, using a 1/4" hex key.

7. Install the floor utility sub-assembly

Route the umbilical (and the floor utility sub-assembly) from the PMU to the floor box. Thread the manual shut-off valves for air and water onto the air and water supply pipes (these should be sealed, for example with Teflon tape).

8. Make Tubing Connections in the PMU

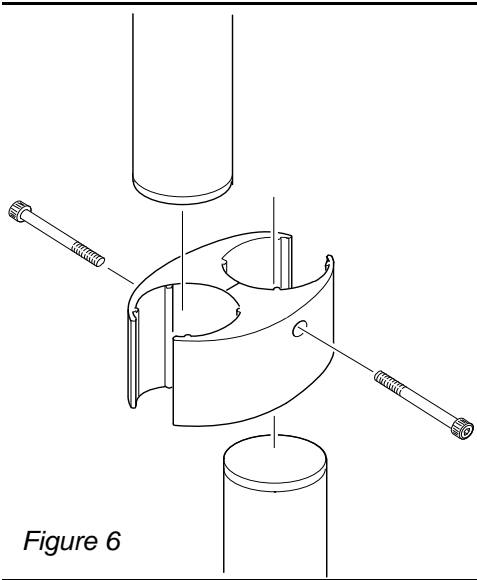

Figure 6

Control Head

- ◆ 1/8" yellow from the control head to 1/8" yellow (pilot air). Both of these lines are labelled with a number "5."
- ◆ 1/8" clear from the control head to 1/8" clear (Unregulated air). Both of these lines are labelled with a "4."
- ◆ 1/8" gray from the control head to regulated air (multi-connector).
- ◆ 1/8" red from the control head to 1/8" red (regulated water).
- ◆ The 1/8" orange line, labelled "A", is unconnected in

the control head. It can be used for any application. To use this line for a chip blower, see the section below on foot control connections.

- ◆ The 1/8" red line in the umbilical, labelled "W", is unconnected too. It is intended to be used when installing a syringe water heater in the system.

Foot Control

Use figure 7 if your foot control has 4-hole tubing. Use figure 8 if it has 5-hole tubing.

Route the foot control tubing through the bottom of the PMU and connect:

- ◆ 1/4" gray ribbed from foot control (air supply) to regulated air supply in the PMU (multi-connector).
- ◆ 1/4" gray unribbed from foot control (drive air) to 1/4" gray from the control head. Both of these lines are labelled "1."
- ◆ 1/8" water coolant signal line from foot control to 1/8" orange from the control head. Both of these lines are labelled "3."
- ◆ 1/8" air coolant line from the foot control to 1/8" white from the control head. Both of these lines are labelled "2."
- ◆ 1/8" chip blower/scaler line from foot control to the unconnected 1/8" orange line from the control head (if applicable). This line is labelled "A." If used for chip blower, connect to air coolant in the control head.

6. Mount the water heater in the floor box using the screws provided.

In the PMU:

1. Locate the cross connector with four 1/4" blue lines and one 1/8" blue line. The 1/8" blue line goes to the city/bottle routing valve. Remove this line and plug the port in the cross connector.
2. Locate the 1/8" red line in the umbilical (the one that's connected to the water outlet barb on the water heater). Connect this line to the city/bottle routing valve in place of the 1/8" blue.

Note:

The water heater and the water lines must be purged of air before turning on the heater.

3. Flip the master toggle on your system to the on position.
4. Press on the syringe water button until a steady stream of water comes out of the syringe.
5. Connect the power cord to 110VAC. If you have purchased the 220 \240 VAC water heater (3112), you will need to install a plug on the end of the power cord. Connect the wires as follows:

Green - Ground
Black - High
White - Low

6. If your water heater is air actuated, it will turn on when you flip the master air toggle on your delivery system to the on position. Manually controlled water heaters have a power switch, located just above the DCI label.
7. Water temperature is adjusted by turning the screw on top of the water heater. Turning the screw clockwise increases water temperature. Turning the screw counter-clockwise decreases the temperature.

Remove the plug from one of the extra ports, and install a 1/8" barb fitting.

3. Connect the water inlet barb on the syringe water heater to the 1/8 barb on the water regulator.

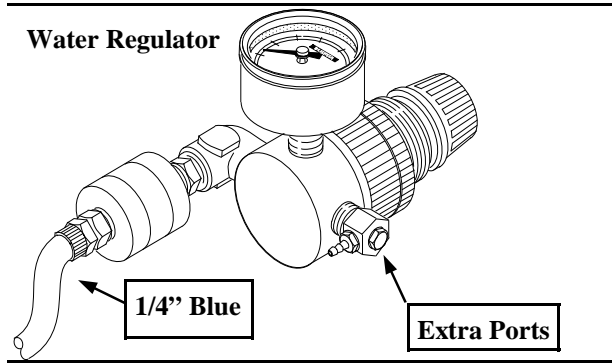

Figure 2

4. Connect the water outlet barb on the water heater to the 1/8" red line in the umbilical.

5. If your water heater is air actuated (model #3111), you will need to connect the air actuated switch to master air. Run a 1/8" line from the barb fitting on the air actuated switch to a tee connection in the master air line (1/8" yellow).

Do not connect the power cord at this time.

Note:

The water heater must be mounted in order to operate safely. It can be mounted either upright or on its side. However, if the water heater is mounted on its side, it must be oriented with the inlet and outlet barbs, and the DCI label, facing up. Orienting the heater any other way could cause it to fail (see figure 3).

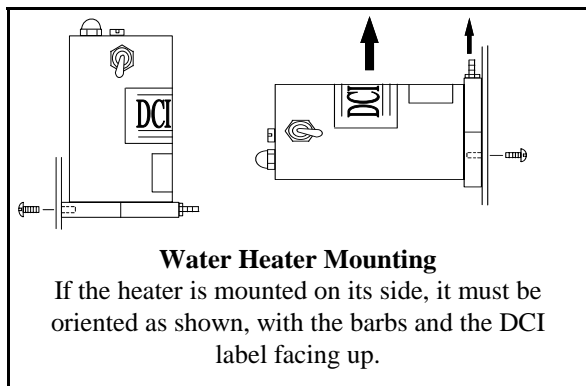

Water Heater Mounting

If the heater is mounted on its side, it must be oriented as shown, with the barbs and the DCI label facing up.

Figure 3

Assistant's Instruments

Route the gray lines from the SE and the HVE through the bottom of the PMU and connect:

- ◆ 1/2" gray from HVE to 1/2" fitting on the solids collector.
- ◆ 1/4" gray from SE to 1/4" fitting on the solids collector.

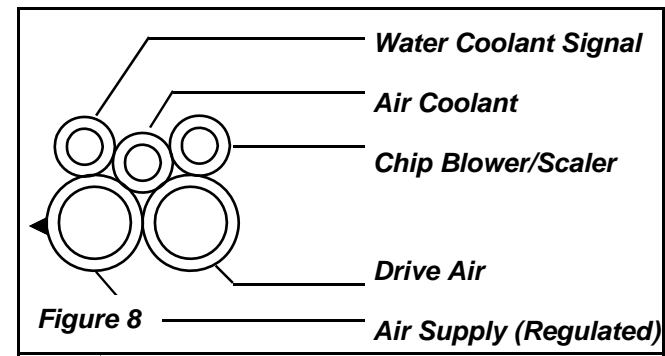
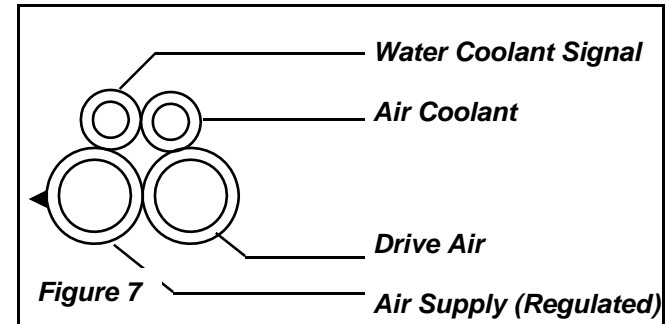

Free end of the foot control tubing will look like these diagrams as it faces

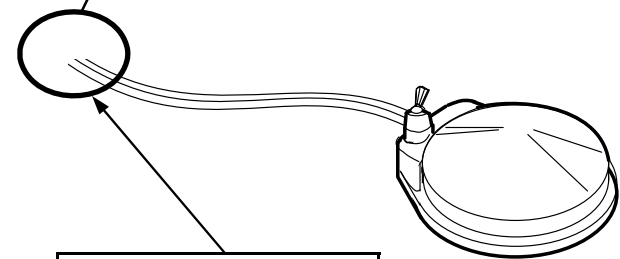

Route the free end of the foot control tubing through the bottom of the PMU.

9. Make Tubing Connections in the Floor Box

Connect:

- ◆ 1½" gray drain tube from the solids collector to vacuum source.
- ◆ Corrugated drain tube from cuspidor to gravity drain.

10. Remove the shipping strap and wrapping from the arm. Install the side covers on the PMU.

11. Turn On and Adjust Air and Water Supply

Open the manual shut-off valves in the floor box. Adjust regulated air to 80 psi, and regulated water to 40 psi. The mini-regulators in the floor box are non-relieving. When adjusting for a lower pressure, make the knob adjustment, then press the syringe button to relieve pressure and give an accurate gauge reading.

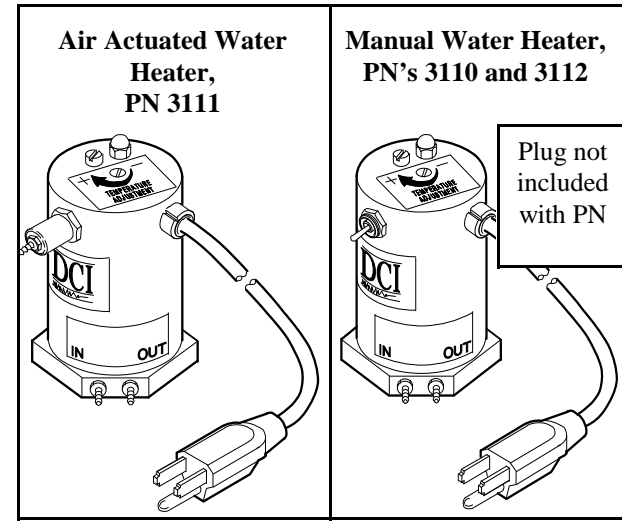

Figure 1

Warning:

The syringe water heater should always be connected to city water. Do not connect your water heater to a bottled water supply. If the water supply to the heater is interrupted, the water heater may overheat, causing failure. This instruction sheet provides a connection scheme which will isolate the water heater from bottled water.

You will need the following tools to install the Syringe Water Heater in your delivery system:

- A Phillips head screwdriver.
- A 1/8" sleeve tool.
- A 1/4" open-end or socket wrench.

It is recommended that the water heater be located in the floor box. This provides easy access to the duplex outlet. See important notes below on how to orient your water heater when mounting, to ensure safe operation.

In the floor utility:

1. Turn off air and water to your system at the manual shut-off valves before installing the water heater.
2. Locate the water regulator in the utility center (see figure 2).