

Committed to Innovation

regulated air supply (at the air regulator).

- ◆ Foot control drive air (un-ribbed line) to the 1/4" gray tubing from the control head (drive air). Both of these lines are labelled "1."
- ◆ 1/8" orange line, labelled "A", to foot control 1/8" outlet from the chip blower/scaler button (if so equipped). This extra 1/8" orange line is unconnected in the control head, and can be used for any application. If used for a chip blower/scaler, connect the free end in the control head to air coolant.
- ◆ 1/8" orange to foot control 1/8" outlet from water coolant signal line. Both of these lines are labelled "3."
- ◆ 1/8" gray to regulated air supply (at the air regulator).
- ◆ 1/8" clear to unregulated air supply (at the air master shut-off valve).
- ◆ 1/8" yellow to the pilot air inlets on top of the shut-off valves. This line is labelled "5."
- ◆ 1/8" red to regulated water (at the water regulator).
- ◆ 1/8" white to foot control 1/8" air coolant line (regulated). Both of these lines are labelled "2."

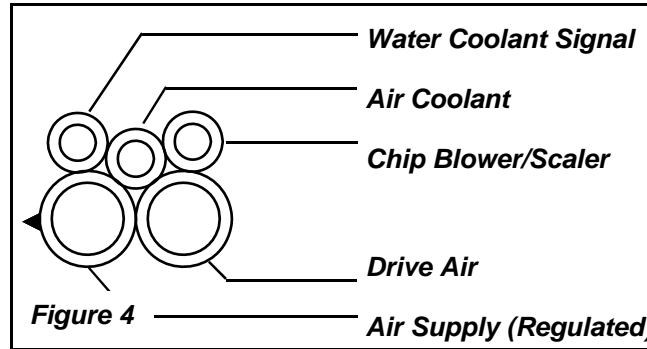
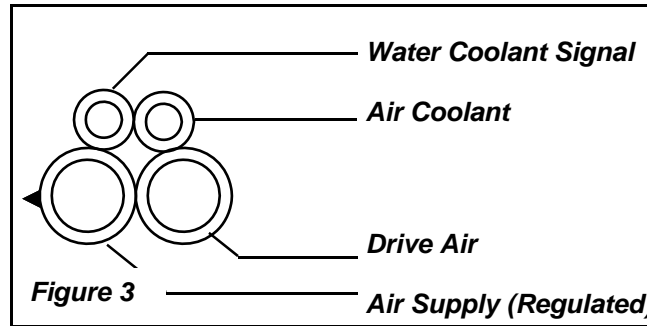

Free end of the foot control tubing will look like these diagrams as it faces

10. Open the manual shut-off valves in the utility center. Adjust regulated air to 80 p.s.i, and regulated water to 40 p.s.i. The mini-regulators are non-relieving. When adjusting for a lower pressure, make the knob adjustment, then press the syringe button to relieve pressure and give an accurate gauge reading.
11. On the underside of the unit, the master on-off is on the left. The handpiece flush toggle is behind the master on-off. Air and water coolant flow control knobs are located on the right underside of the unit, toward the rear. The toggle for the pneumatic arm brake is on the right underside, in front of the coolant flow control knobs.

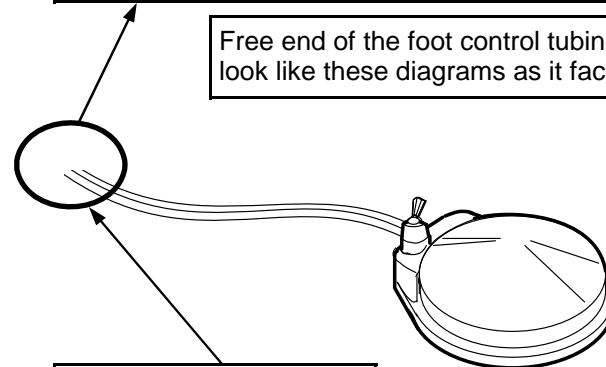

Route the free end of the foot control tubing through the bottom of the PMU.

Installation Instructions for the System 6000, Model #6555

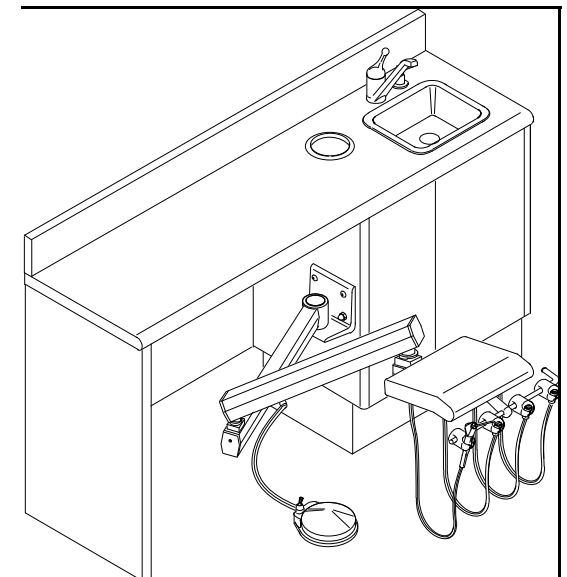

WARNING

The arm assembly for this unit is spring loaded. Do not remove the shipping strap from the arm assembly until the unit is fully installed. Bodily injury could result from working with the arm assembly unrestrained.

The following items are contained in this package:

- ◆ One arm and control head assembly, with handpiece tubings, umbilical and mounting plate installed.
- ◆ One wet/dry foot control.
- ◆ One Quick Clean standard syringe.
- ◆ One standard syringe kit.
- ◆ One stainless steel tray.
- ◆ One anti-skid pad.
- ◆ One hardware kit containing:
 - Three mounting screws (bh socket, 1 and 3/4" long).
 - One threaded rod with nylon cap nut.
 - One nylon cap screw.
 - Four washers.
 - Four hex nuts.

You will need the following tools and materials to install the 6555:

- ◆ 1/2" drive electric drill.
- ◆ 7/16 drill bit.
- ◆ Hex keys: 5/16", 7/32".
- ◆ 9/16" open end wrench.
- ◆ 1/4" and 1/8" sleeve tools.
- ◆ Level

NOTE

It is essential that the mounting plate be securely attached to a rigid structure. Some cabinets are pre-drilled from the back side to fit the mounting bracket. Do not mount the unit over pre-drilled or pre-cut areas.

1. The delivery system mounting location must allow the instrumentation to easily reach the desired working area at the dental chair. Maximum distance from the mounting surface to the outer edge of the work surface is 60". Maximum vertical travel of the work surface is 20".
2. Drill four 7/16" dia. holes as shown in *Figure 1*.
3. Lift the arm assembly out of the carton and set the

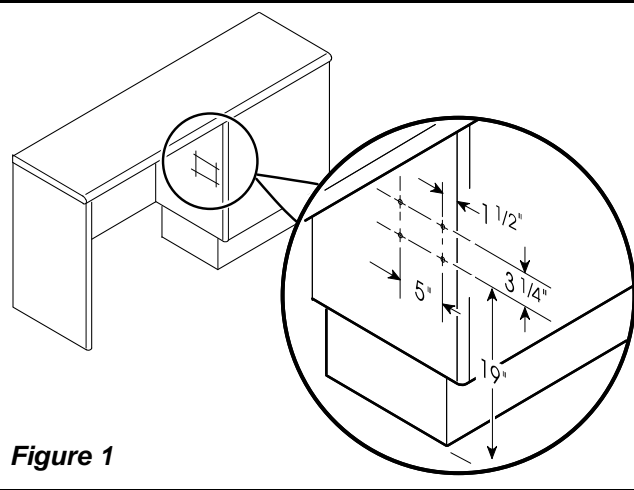

Figure 1

hardware package aside. **Leave the shipping strap on the arm assembly.**

4. Carefully position the unit against the mounting surface with the top two mounting screws through the bracket.
5. Place a nut and washer on both screws. Snug them down, but do not fully tighten them. Install the

remaining mounting screw and the threaded rod with nylon cap nut in the bottom of the bracket and snug them down as well. Refer to *Figure 2* for placement of the threaded rod with nylon cap nut.

6. Level the unit by slightly loosening the mounting screws and rotating the bracket. When you are

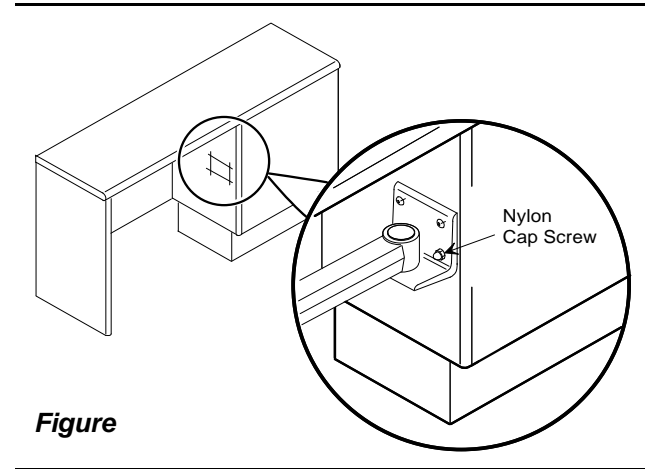

Figure

satisfied that the unit is level, fully tighten all four mounting screws.

7. If your unit is mounted in a cabinet, route the umbilical through the hole provided in the cabinet toeboard and into the utility center.
8. Install the utility center sub-assembly. A separate instruction sheet is provided.
9. Make tubing connections in the utility center as follows:
 - ◆ Foot control air supply (ribbed line) to