

ALTERNATIVE #44 I I CART SYSTEM

Installation Instructions



Note: If product is received in the U.S. Cart is fully assembled, simply remove from box and skip to step 9 in instructions.

This package contains two assemblies:

1. H-frame cart
2. Control unit.

The H-frame cart assembly contains the following items:

- One H-frame with caster fittings pre-installed.
- A separate box containing:
 - One telescoping post assembly.
 - One height adjustment collar.
 - One post mounting bolt (1/2" x 13).
- A hardware kit containing:
 - Four casters.
 - One height adjustment knob with threaded shaft.
 - Four 1.75" diameter plugs.
 - Two .75" diameter plugs.

The control unit assembly contains the following items:

- One control unit with handpiece tubings and umbilical tubings attached.
- One standard syringe.
- One syringe kit.
- One standard foot control.
- One 3/32" ball driver.

You will need the following tools and materials to assemble the 44 I I:

- 3/4" box-end wrench.
- 3/32" hex key.
- Level.
- 1/4" and 1/8" sleeve tools.
- Tubing sleeves and fittings.

To assemble the H-frame cart (see *Figure 1*):

1. Remove all the parts from their packages and put them on a table.
2. Hold the H-frame upright on the table and thread the post mounting bolt through the hole in the cross-piece. Thread the mounting bolt into the threaded hole in the bottom of the telescoping post assembly. Tighten the bolt snugly (40-50 ft-lbs) with a 3/4" box-end wrench.
3. Press the casters into the fittings on the bottom of the H-frame. The clip rings on the casters provide a friction fit.
4. Press the four 1.75" diameter plugs into the ends of the H-frame tubes. Press the .75" diameter plugs into the holes in the crosspiece. Set the cart frame on the floor.
5. Thread the height adjust knob into the height adjust collar. Slide this assembly over the telescoping post assembly, and position it so that the end of the knob is over the hole in the outer post. Thread the knob into the hole, just far enough to allow the collar to stay in place.
6. Lift the inner post about four inches and rotate it. You will see a 3/8" slot in the post. Rotate the inner post until the slot is aligned with the height adjustment knob. Thread the knob through the slot to the opposite wall of the inner post.

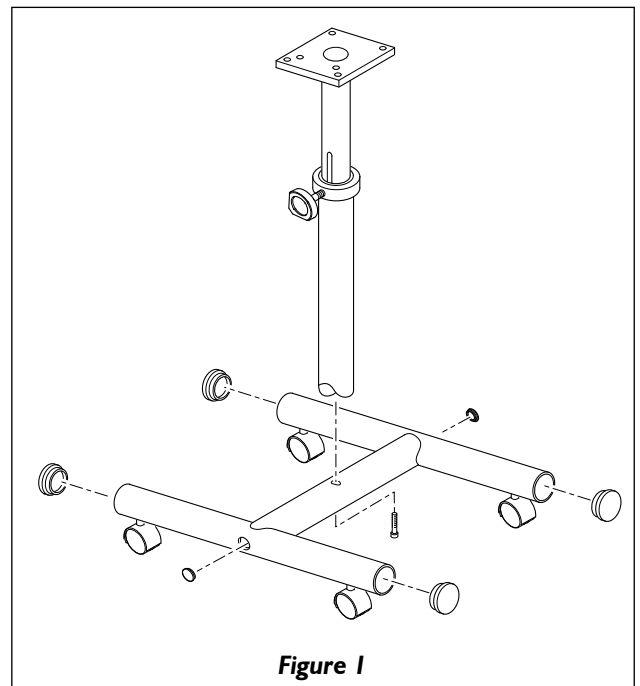

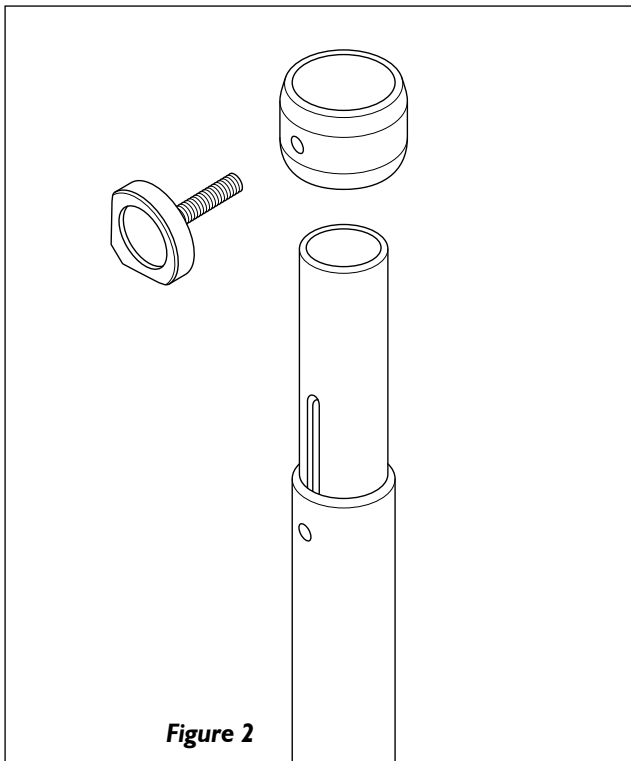

Figure 2

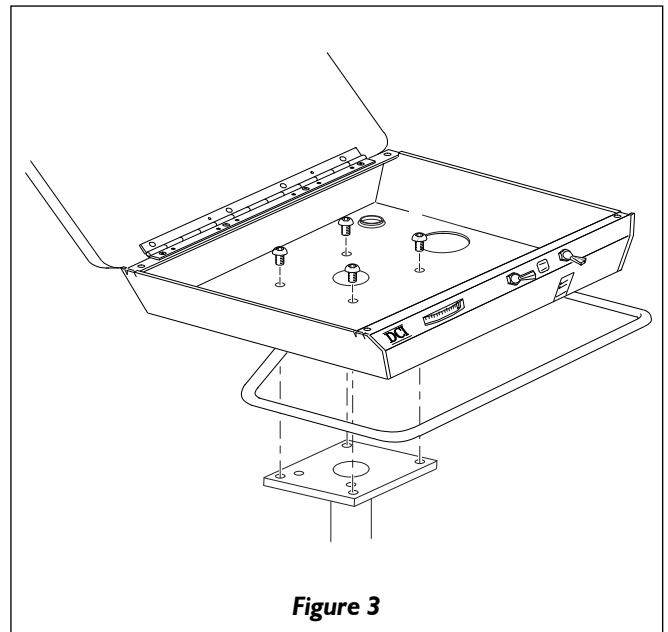

Figure 3

7. To adjust the height of the post (see *Figure 2*):
 - a. Loosen the knob.
 - b. Raise the inner post to the desired height. The slot in the inner post provides a minimum and maximum stop height for the post assembly.
 - c. Tighten the knob against the inner post.
8. To assemble the control head to the cart (see *Figure 3*):
 - a. The post mounting plate is attached to the base of the control head assembly. The plate has a round fitting with four set screws for the post. Position the fitting over the inner post on the cart.
 - b. Level the control head and tighten the set screws using a 3/32" hex key.
9. To make utility connections:
 - a. Route the 3/4" umbilical to the utility center. Connect:
 - 1/8" red to regulated water.
 - 1/4" gray to regulated air.
 - b. Open the manual shut-off valves in the utility center. Adjust regulated air to 80 p.s.i. and regulated water to 40 p.s.i. The mini-regulators are non-relieving. When adjusting for a lower pressure, make the knob adjustment, then press the syringe button to relieve pressure and give an accurate gauge reading.
 - c. The handpiece pressure gauge is on the left side of the faceplate. The water coolant on-off toggle is on the right. Water coolant flow control knobs are on the underside of the control head.
 - d. Adjustment screws for the handpieces and the syringe can be reached through holes in the base of the control head. Use the 3/32" ball driver to adjust handpiece pressures to the manufacturer's recommendation.
 - e. Handpieces operate automatically when the lockout toggles on the holders are positioned toward the red dot.