

34 AND 50 INCH FLEX ARM Installation & Operating Instructions



Tools needed:

- Allen wrench selection
- Post leveling tool

Kit Content:

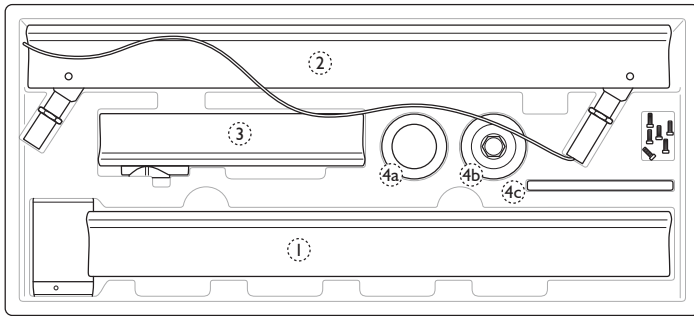

Figure 1. Flex Arm Kit Content

<u>Item</u>	<u>Description</u>
1	Rigid Arm Assembly
2	Flex Arm Assembly
3	Unit Mount Rigid Arm
4	Hardware:
	a. Collar Stop Post
	b. Stop washer, Snap ring, Spacer, Screws (2), Knuckle Cover
	c. Bearing strips

Installation Instructions

1. Remove belly strips from the Flex Arm Assembly (Item 2) and Rigid Arm Assembly (Item 1).
2. Remove end caps from Item 1 and Item 3.
3. **Post (not included):** Install a 2 inch post in the chair adapter of the dental chair. Level the post utilizing the manufacturer's post leveling adjustments. To prevent unit from drifting, the post must be leveled.
4. **Collar:** Slide the collar onto the post to the desired height of the rigid section of the flex arm in relation to the seat of the chair. Tighten the 3 set screws in the side of the collar with a 3/32in hex key. **Note:** Some chair seats will rise as the patient is put in the supine position. Be sure to place the collar with the chair in this position. Slide the plastic washer on top of the collar.
5. **Installing Arm:** Place bearing strips into the grooves inside the hub portion and then slide the hub portion of the unit arm down the post on top of the collar. **Note:** Additional bearing strips are provided with different thicknesses due to variances in finishes on posts. Use appropriate bearing strips in the arm hub to post play.

6. **Supply Tubing:** Refer to appropriate dental unit installation instructions for correct tubing hookup. The black tubing in flex arm should be routed to unit head and hooked up to a momentary 'brake' 3-way toggle that is normally open.

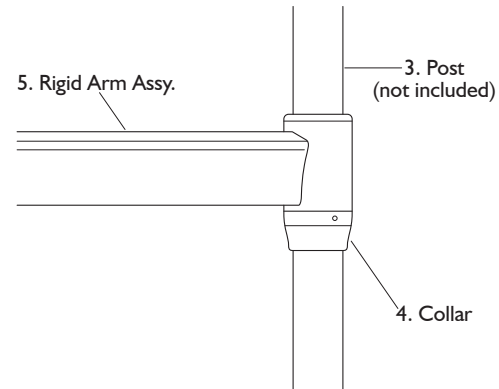

Figure 2. Steps 3 – 5 Rigid Arm to Post Installation

7. **Attach Bracket Assembly:** Remove bracket from Unit Mount Rigid Arm and attach to knuckle on flex arm assembly as shown in Figure 3.

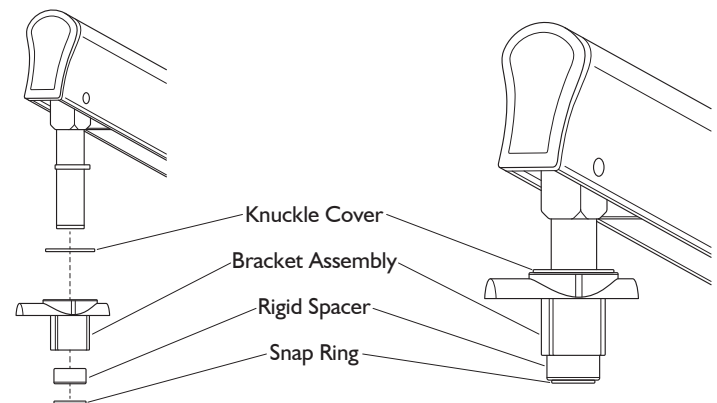

Figure 3. Install Bracket Assembly to Flex Arm

8. **Attach Unit Mount Arm:** Attach the Unit Mount Rigid Arm to the bracket/flex arm assembly, replace covers on ends of Unit Mount Rigid Arm. Raise Knuckle cover and install two dowel pins into bracket assembly. See Figure 4.

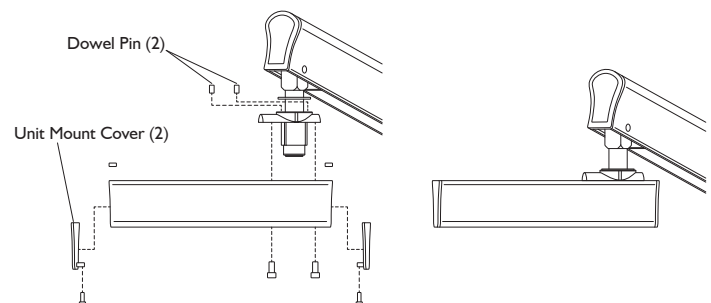
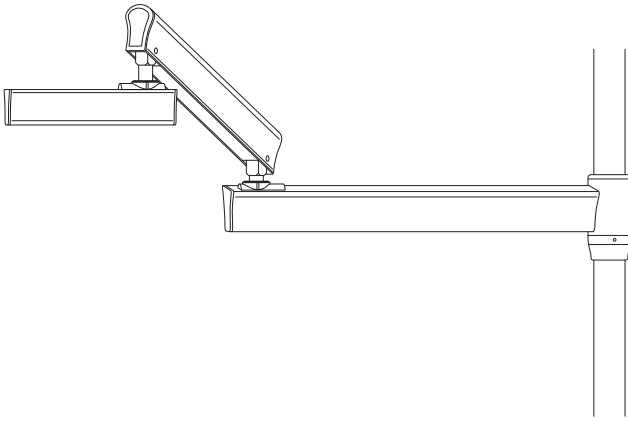

Figure 4. Attach Unit Mount Rigid Arm to Flex Arm

9. Installed Flex Arm:



Operation of Flex Arm and Features

The *pneumatic arm brake toggle* is located on the underside of the control unit, in the front right corner or front left corner- if unit is left handed. The brake keeps the vertical position of the arm assembly constant until the operator chooses to change it. To change the vertical position of the arm, pull the toggle forward to release the brake, reposition the arm to the desired position and release the toggle. It may be necessary to adjust the spring tension on the flex arm section of the pneumatic arm, depending on the extra weight added to the instrument tray. If the control unit drifts out of the vertical position when the brake is released, extend the arm assembly fully and position it at its highest vertical height. Slide the long plastic strip out to expose the supply tubing running inside the arm. See **Figure 5**. The opening under the tubing provides access to the handle for the tension adjustment. The handle is located underneath the supply tubing and will present itself if the tubing is moved to one side. Spring tension is adjusted by moving the handle either to the left or the right. If the control unit drifts up, move the handle counterclockwise (as viewed from front of control unit) to reduce tension – disengage collar by moving handle toward the unit head – advance the handle and reengage – repeat until desired tension is achieved. If the control unit drifts down, move the handle clockwise (as viewed from front of control unit) to increase tension – disengage collar by moving handle toward the unit head – advance the handle and reengage – repeat until desired tension is achieved. Replace tubing back to original position and slide the long plastic strip back into place – the tension adjustment handle will fold out of the way automatically.

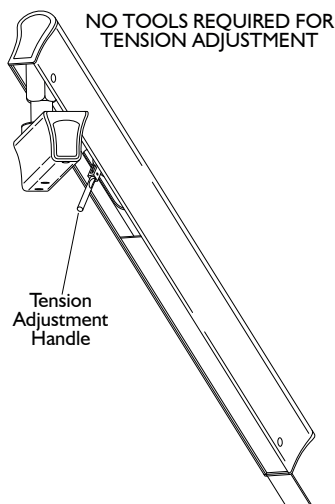

Figure 5. Tension Adjustment

Adjustable pin stop: Rigid arm to flex section.

Factory set at the most common rotational stops. To adjust:

1. Slide cover up and twist at slotted area and slide over knuckle.
2. Rotate arm to gain access – remove pin and replace in desired rotational stop – there are 12 areas to place the stop.
3. Replace cover.

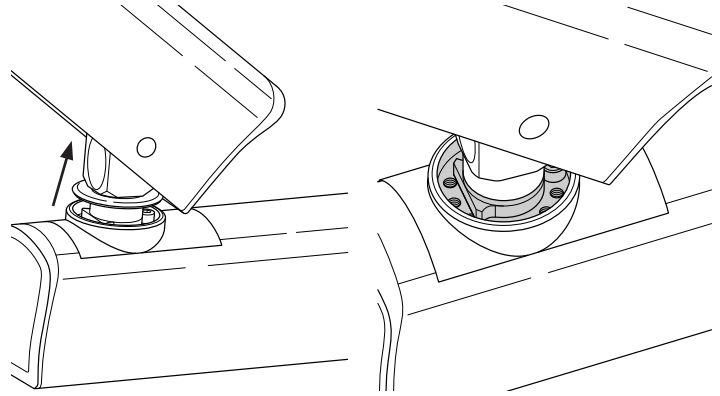

Figure 6. Adjustable Pin Stop: Rigid Arm to Flex Section

Adjustable pin stop: Flex section to small Unit Mount Rigid Arm.

Factory set at the most common rotational stops. To adjust:

1. Slide cover up and twist at slotted area and slide over knuckle.
2. Rotate arm to gain access – remove pin and replace in desired rotational stop – there are 12 areas to place the stop.
3. Replace cover.

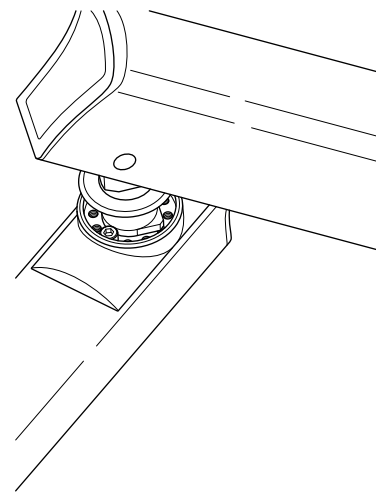

Figure 7. Adjustable Pin Stop: Flex Section to Small Unit Mount Rigid Arm