

SERIES 4 AUTOMATIC UNIT 4477 & 4478

Installation and Operating Instructions



Package contains:

- 50" Flex arm 8733 white or 8735 Gray, Automatic control unit with umbilical and tubing

Note: 34" flex arms 8734 or 8735 are available as options

- Precision Comfort syringe
- Wet/Dry foot control
- 2" Post collar
- Bearing strip kit
- Stainless steel tray with holder
- Syringe repair kit

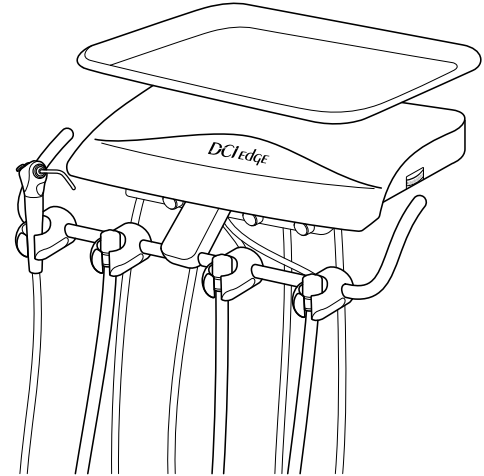

Tools needed:

- 1/4" and 1/8" sleeve tool
- Small and large flat blade screwdriver
- Post leveling tool

INSTALLATION INSTRUCTIONS



WARNING: The arm assembly for this control unit is spring loaded. Do not remove the shipping strap from the arm until the control unit is fully installed. Bodily injury could result from working with the arm assembly unrestrained.

- 1. Post:** Install a 2" post in the chair adapter of the dental chair. Level the post utilizing the manufacturer's post leveling adjustments. To prevent unit drifting, the post must be perfectly leveled.
- 2. Collar:** Slide the collar onto the post to the desired height of the rigid section of the flex arm in relation to the seat of the chair. Tighten the 3 set screws in the side of the collar with a 3/32" hex key. **NOTE:** Some chair seats will rise as the patient is put in the supine position. Be sure to place the collar with the chair in this position. Slide the plastic washer on top of the collar.
- 3. Unit Arm:** Slide the hub portion of the unit arm down the post on top of the collar. **NOTE:** Additional bearing strips are provided with different thicknesses due to variances in finish on the posts. Use appropriate bearing strips in the arm hub to provide smooth action with no hub to post play. Remove the shipping strap from the arm and unwrap.

Note: Other mounting options available. Contact Customer Service for support

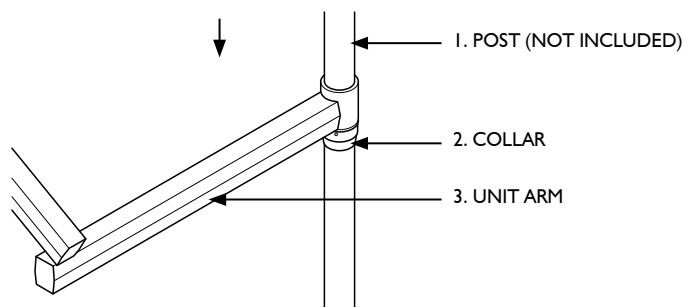

STEPS 1 - 3

4. Umbilical Tubing: Run unit umbilical tubings either into post hole or directly into junction box at the base of the chair. Connect proper tubings to utility center:

- 1/8" Red - Water supply
- 1/8" Clear - Unregulated air supply
- 1/8" Yellow - Signal air to shut-off blocks
- 1/8" Gray - Regulated air
- 1/8" Orange - Foot control water relay
- 1/4" Gray - Regulated drive air/air coolant
- 8 conductor low voltage power cord, as needed

5. Water and Air Supply: Open the manual shut-off valves in the utility center. Adjust regulated air to 80 psi and regulated water to 40 psi. When adjusting for a lower pressure, make the adjustment, and then press the syringe button to relieve the pressure to get an accurate pressure reading.

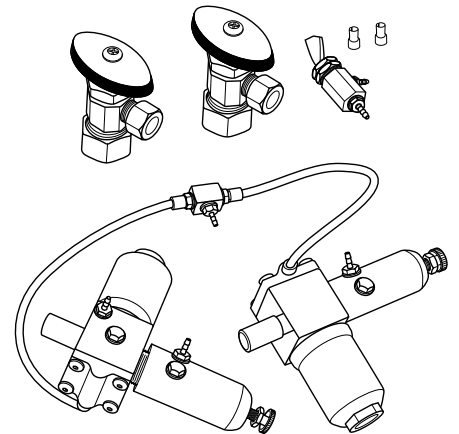

STEPS 4 - 5 UTILITY CENTER NOT INCLUDED

OPERATING INSTRUCTIONS AND UNIT FEATURES

HANDPIECE HOLDERS

The asepsis handpiece holders are designed to resist chemical discoloration and be easy to clean. The handpiece is activated when removed from the holder and stepping on the foot control disc. The positions of the individual handpiece holders are adjustable, loosen the set screws, move the instrument holder to the desired location, and retighten the screws. You will need a 1/8" hex key. See Figure 1.

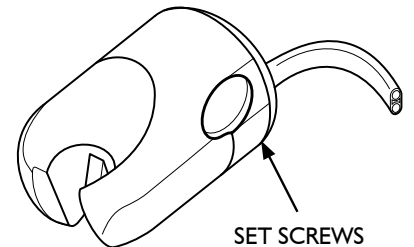

FIGURE 1

CONTROLS

The *master on-off toggle* controls air and water to the entire system. It is located on the underside of the control unit, on the left. The *water coolant flow control knobs* control water to a specific handpiece and are located on the underside of the control unit, near the front. The *handpiece flush toggle* is located on the underside of the control unit on the left of the unit - used to flush handpieces. The *drive air pressure gauge* indicates the operating pressure of the selected handpiece. It is located on the right side of the control unit chassis. The *drive air adjustment screws* are located on the inside of the control unit, in the back. To gain access - remove screw retaining cover using a 3/32" hex driver - lift cover up and remove from rear hinge. Handpiece drive air pressure should be adjusted to the handpiece manufacturer's recommendation. See Figure 2.

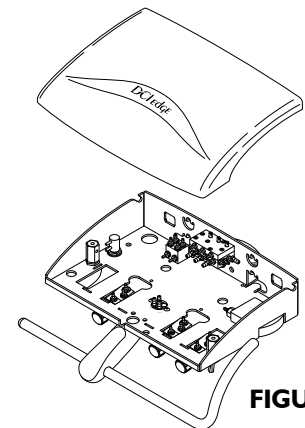
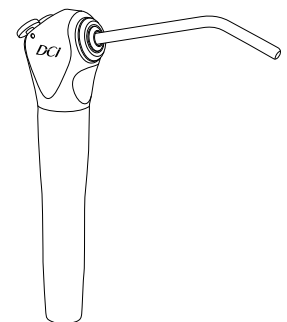

FIGURE 2

SYRINGE

The Unit comes with a Precision Comfort syringe. The syringe is packaged in a shipping envelope, with operating instructions and a repair kit attached. The syringe goes in the holder on the far left side of the instrument holder bar. Adjustment screws for the air and water flow to the syringe are located on the underside of the control unit, in the rear left area. Use the 3/32" hex driver provided with the unit to turn the hex screws counterclockwise to increase the flow of air or water, clockwise to decrease the flow.



FOOT CONTROL

The foot control is equipped with a wet/dry toggle. When the toggle is positioned toward the blue dot, water will be provided to the active handpiece. With the toggle positioned away from the blue dot, water is turned off. Handpiece speed is controlled with the foot control disc. Varying pressure on the foot control disc controls speed. Air coolant is also provided when you step on the foot control disc.

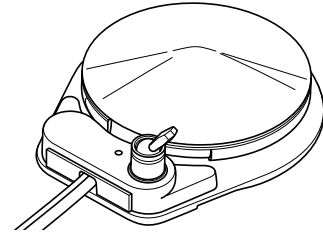

CONTROL HEAD

The control head can be cleaned with most commonly available surface disinfectants. Do not use any Sodium Hypochloride solutions, or any cleansers containing alcohol. These may cause paint and finish discoloration.

DENTAL UNIT WATER LINE MAINTENANCE

Distilled water is not recommended for use in dental units. The Centers for Disease Control and the American Dental Association can provide recommendations on when to flush your system, for how long, and what products to use.

CLEANING AND MAINTENANCE

Do not use powdered cleansers, scouring pads, or abrasive scrubbers on any of the finished metal surfaces in this unit, i.e., the syringe or the foot control disc. Sodium Hypochloride will also damage these surfaces.

The handpiece oil collector is located on underside of unit in center, unscrew base to reveal gauze, replace weekly if necessary with 2" x 2" gauze pad.

FLEX ARM

The *pneumatic arm brake toggle* is located on the underside of the control unit, in the front right corner or front left corner- if unit is left handed. The brake keeps the vertical position of the arm assembly constant until the operator chooses to change it. To change the vertical position of the arm, pull the toggle forward to release the brake, reposition the arm to the desired position and release the toggle. It may be necessary to adjust the spring tension on the flex arm section of the pneumatic arm, depending on the extra weight added to the instrument tray. If the control unit drifts out of the vertical position when the brake is released extend the arm assembly fully and position it at its highest vertical height. Slide the long plastic strip out to expose the supply tubing running inside the arm (See Figure 3). The opening under the tubing provides access to the handle for the tension adjustment. The handle is located underneath the supply tubing and will present itself if the tubing is moved to one side. Spring tension is adjusted by moving the handle either to the left or the right. If the control unit drifts up, move the handle counterclockwise (as viewed from front of control unit) to reduce tension - disengage collar by moving handle toward the unit head - advance the handle and reengage - repeat until desired tension is achieved. If the control unit drifts down, move the handle clockwise (as viewed from front of control unit) to increase tension - disengage collar by moving handle toward the unit head - advance the handle and reengage - repeat until desired tension is achieved. Replace tubing back to original position and slide the long plastic strip back into place - the tension adjustment handle will fold out of the way automatically.

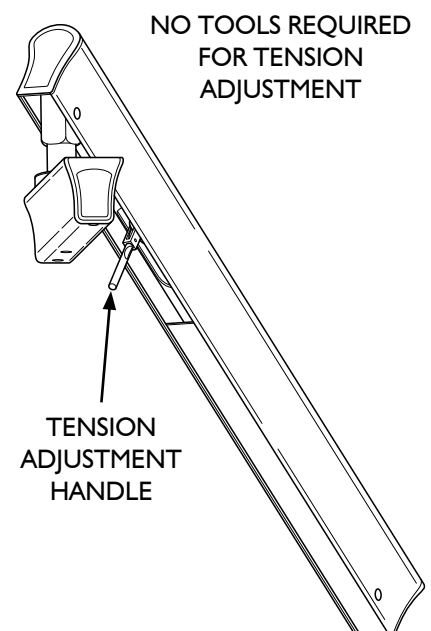

FIGURE 3

OPERATION OF FLEX ARM AND FEATURES

Adjustable pin stop: Rigid arm to flex section.

Factory set at the most common rotational stops. To adjust:

1. Slide cover up and twist at slotted area and slide over knuckle.
2. Rotate arm to gain access - remove pin and replace in desired rotational stop - there are 12 areas to place the stop.
3. Replace cover.

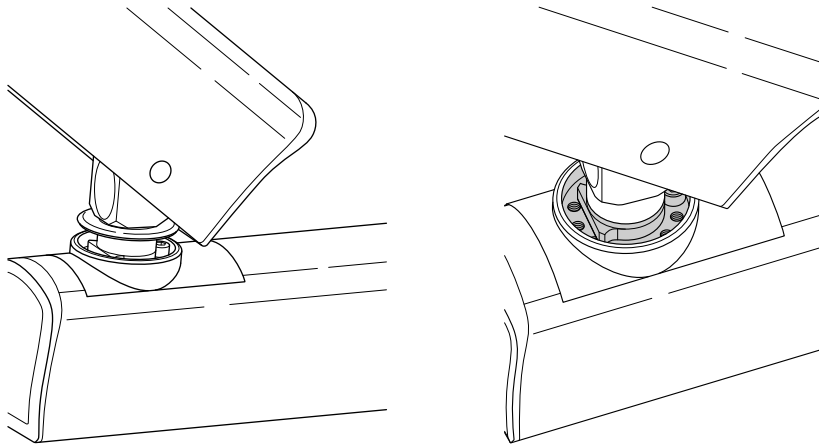

FIGURE 4. ADJUSTABLE PIN STOP: RIGID ARM TO FLEX SECTION

Adjustable pin stop: Flex section to small Unit Mount Rigid Arm.

Factory set at the most common rotational stops. To adjust:

1. Slide cover up and twist at slotted area and slide over knuckle.
2. Rotate arm to gain access - remove pin and replace in desired rotational stop - there are 12 areas to place the stop.
3. Replace cover.

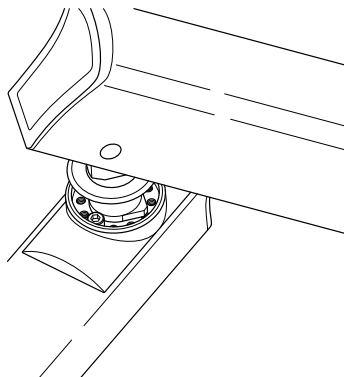

FIGURE 5. ADJUSTABLE PIN STOP: FLEX SECTION TO SMALL UNIT MOUNT RIGID ARM

